

Case Study: Food Service Equipment Motor Price Dropped by Power Electric

Our food service equipment manufacturer worked with a motor manufacturer already. We approached them with an opportunity to obtain better pricing while maintaining their current quality and performance.

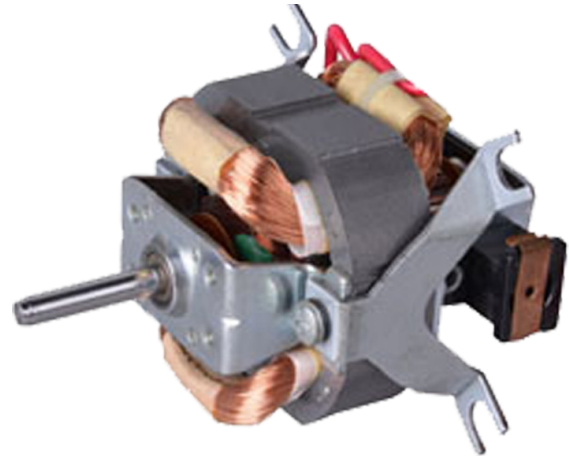

We worked with our contracted manufacturers and priced a motor with the same form, fit and function as their previous motor. The quality was unchanged, the performance level was unchanged and the price dropped. We were able to provide a better value for this food service equipment motor, saving the company 20-30%. In addition to saving this customer money, by managing inventory we gave them warehouse inventory options with smaller shipment sizes increasing their inventory turns.

Power Electric is able to offer better motor value through our long-standing and contracted relationships with international motor manufacturers while placing strong emphasis on quality having our team based in China.

Motor Requirements

- Space restraints require a right angle gear motor
- Clockwise rotation
- Smooth start without hesitation at low power

Motor Selection

- Universal AC motor
- Current: 0.73A
- Power: 160w
- Speed: 15,000rpm
- Torque: 47.8MN.m
- Input Power: 75w
- Efficiency: 46.9%

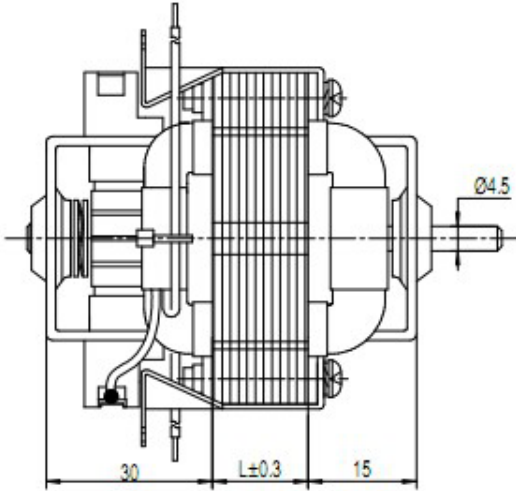
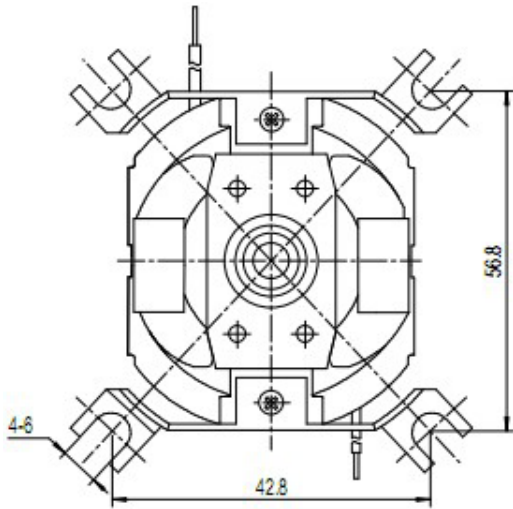
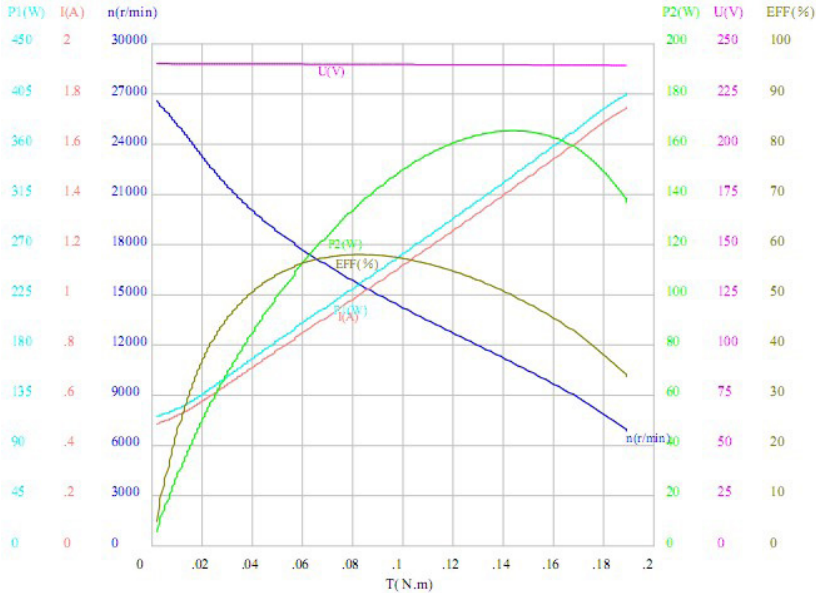

Power Electric works with food & beverage preparation equipment companies throughout the US, assisting customers with motor and gear motor solutions for their projects. Connect with our in-house engineering experts for custom electric motors or find support choosing the right product for your food and beverage applications by calling 763-383-6936.

The World's Largest Source of Small Electric Motors